

# MICRO

## SIFONE MECCANICO A SECCO ISPEZIONABILE

*Sifón mecánico a seco inspeccionable*

*Dry mechanical inspectionable trap*

### Caratteristiche principali

- Colonna di chiusura idraulica da 30 mm
- Raccordo adattatore Ø 18 mm
- Componenti interni smontabili per ispezione e pulizia periodica
- Corpo del sifone realizzato con limitare dimensioni di ingombro
- Montaggio reversibile dx e sx, sia con scatola da incasso a muro che senza
- Uscita dello scarico da Ø 16/18 mm e Ø 18/20 mm per tubi corrugati ns. articoli 9899-050/051/052/053-01
- L'uscita acqua può essere verticale utilizzando il raccordo a gomito a 90° opzionale
- Il sifone funziona solo in senso verticale con il raccordo adattatore Ø 18 mm posizionato in alto.
- Completo di guarnizione tecnica O-ring
- Portata 30 l/h

### Principales características

- Cierre hidráulico 30 mm
- Adaptador conector Ø 18 mm
- Componentes internos extraíbles para inspección y limpieza periódicas
- Cuerpo sifón hecho con dimensiones generales limitadas
- Montaje reversible a derecha e izquierda, con o sin caja empotrada en la pared
- Salida de desagüe Ø 16/18 mm y Ø 18/20 mm para tubos corrugados, nuestros artículos 9899-050/051/052/053-01
- La salida de agua puede ser vertical utilizando el conector a codo a 90° opcional
- El sifón sólo funciona verticalmente con el conector adaptador Ø 18 mm hacia arriba.
- Completo con junta tórica
- Capacidad 30 l/h

### Main features

- 30 mm water seal
- Adapter connector Ø 18 mm
- Removable internal components for periodic inspection and cleaning
- Body trap made with reduced overall dimensions
- Right and left reversible assembly, both with or without wall recessed box
- Ø 16/18 mm and Ø 18/20 mm drain output for corrugated pipes (our items 9899-050/051/052/053-01)
- Possibility of vertical outlet by using the optional 90° elbow connector
- The trap only works vertically with the Ø 18 mm adapter positioned on top
- Complete with O-ring technical gasket
- Capacity 30 liters/h



**SCARICO REVERSIBILE**  
*DESCARGA REVERSIBLE*  
*REVERSIBLE OUTLET*

**IN USO**  
*EN FUNCIÓN*  
*IN USE*

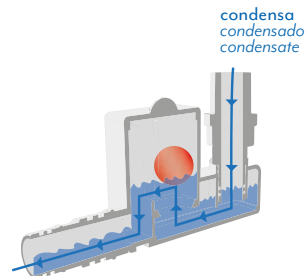

**A RIPOSO**  
*APAGADO*  
*AT REST*

**cattivi odori**  
*malos olores*  
*bad smells*

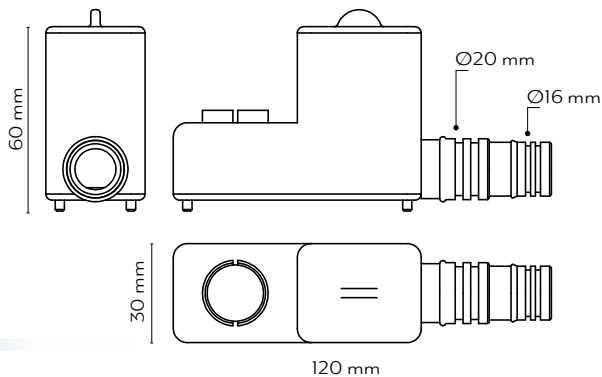
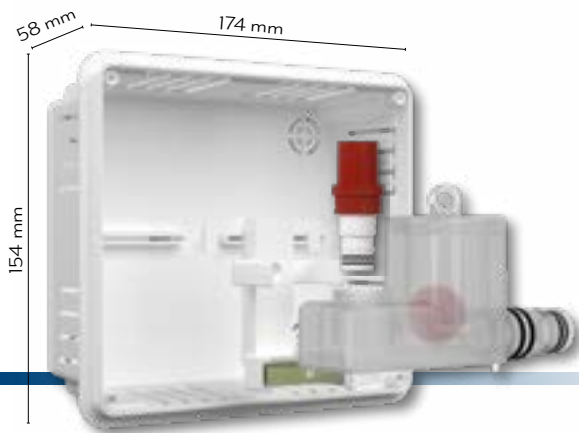
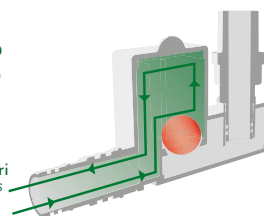

## KIT SIFONE MECCANICO A SECCO ISPEZIONABILE "MICRO"

*Kit sifón mecánico a seco inspeccionable "MICRO"*

*Dry mechanical inspectionable "MICRO" trap kit*

- Sifone a secco Micro
- Installazione DX o SX
- Completo di staffa di supporto con bolla
- O-ring di tenuta
- Scatola con coperchio e viti
- Raccordo adattatore Ø 18 mm
- Sifón seco Micro
- Instalación derecha o izquierda
- Dotado de estribo de soporte con burbuja
- Junta tórica de estanqueidad
- Caja con tapa y tornillos
- Empalme adaptador Ø 18 mm
- Micro dry trap
- RIGHT or LEFT installation
- Equipped with a bracket and ball level
- Seal O-ring
- Box with lid and screws
- Ø 18 mm adapter joint



cod

9899-244-01

## SIFONE MECCANICO A SECCO ISPEZIONABILE "MICRO"

*Sifón mecánico a seco inspeccionable "MICRO"*

*Dry mechanical inspectionable "MICRO" trap*

cod

9899-245-00



Esempio di installazione

Ejemplo de instalación | Installation example

